



**SEWER SYSTEM
CONSTRUCTION SPECIFICATIONS**

JEFFERSON COUNTY PUBLIC SEWER DISTRICT

(REVISED 09/28/2023)

**PO. BOX 632
HILLSBORO, MO 63050**

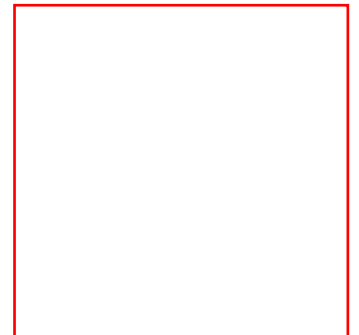

TABLE OF CONTENTS

SECTION 1 - SEWER SYSTEM MATERIALS

| | <u>PAGE</u> |
|--|-------------|
| 1. GENERAL | 3 |
| 2. PIPE AND FITTINGS | 3 |
| 3. MANHOLES | 4 |
| 4. BEDDING MATERIAL | 4 |
| 5. CASING PIPES | 4 |
| 6. PIPE SPACERS IN CASING PIPES | 5 |
| 7. CONCRETE FOR FORCE MAIN THRUST BLOCKS | 5 |
| 8. GRAVITY SERVICE CONNECTIONS | 5 |
| 9. CONNECTIONS TO FORCE MAINS | 5 |
| 10. AIR RELIEF VALVES ON FORCE MAINS | 5 |
| 11. TRACER WIRE ON FORCE MAINS | 5 |

SECTION 2 -SEWER SYSTEM INSTALLATION

| | |
|--|----|
| 1. GENERAL | 6 |
| 2. SITE WORK AND PREPARATION | 6 |
| 3. DRAINAGE | 6 |
| 4. STAKING, ALIGNMENT AND GRADES | 6 |
| 5. SEPARATION OF WATER SYSTEMS AND SEWERS | 7 |
| 6. HANDLING OF MATERIALS | 7 |
| 7. TRENCH EXCAVATION AND BACKFILLING | 8 |
| 8. PIPE INSTALLATION | 8 |
| 9. TRACE WIRE INSTALLATIONS ON FORCE MAINS | 9 |
| 10. MANHOLE INSTALLATIONS | 9 |
| 11. WORK ADJACENT TO AND/OR CROSSINGS OF STATE OR COUNTY HIGHWAYS | 9 |
| 12. CREEK CROSSINGS | 10 |
| 13. INSTALLATION OF AIR RELEASE VALVES AND VAULTS | 10 |
| 14. INSPECTION AND TESTING | 10 |
| 15. SITE CLEANUP, RESTORATION AND GRADING | 11 |
| 16. AS BUILT DRAWINGS | 11 |
| 17. GUARANTEE | 11 |

| | DETAILS | PAGE |
|-------------|-------------------------------|-------------|
| DETAIL A | TYPICAL TRENCH SECTION | 12 |
| DETAIL B | TYPICAL MANHOLE | 13 |
| DETAIL C | TYPICAL DROP MANHOLE | 14 |
| DETAIL D | THRUST BLOCKS FOR FORCE MAINS | 15 |

SECTION 1 - SEWER SYSTEM MATERIALS

1. GENERAL

Material for use at any location in the Sewer System shall meet the requirements as set forth under this Section. Where references are made to standards such as AWWA, ANSI, ASTM, etc., it shall be understood that such references are made to the latest revisions of such standards. When requested by the District, Contractors shall furnish affidavits from their suppliers certifying that materials conform to stated standards before being incorporated in the work. All materials shall be in accordance with MDNR Rules under Title 10 CSR 20-8.120 and 130 or current revision.

2. PIPE AND FITTINGS

a. Pipe for collection systems shall be PVC pipe (except where ductile iron pipe is required as called for later in these specifications) with a standard dimension ratio (SDR) of 35. Pipe and fittings shall conform to ASTM D 3034 "Standard Specification for Type PSM Polyvinyl Chloride (PVC) Sewer Pipe and Fittings". The pipe shall be furnished in 13' or 20' laying lengths. The pipe shall be made and jointed with integral bell and spigot rubber gasketed joints. Each integral bell joint shall consist of a formed bell complete with a single rubber gasket. Gaskets shall conform to ASTM F 477 and meet ASTM D 3212 Specifications. The pipe shall be made of PVC having a cell classification as defined in ASTM D 1784 for 12454 B or 12454 C cell classifications.

b. Pipe for sewer force mains shall be PVC pipe with a standard dimension ratio (SDR) of 21 and be rated for a working pressure of 200 PSI at 73.4 degrees F. and meet all applicable requirements as set forth under Commercial Standard (CS) 256-63. Pipe joints shall be as specified above for PVC pipe for collection systems. All fittings for bends in force mains shall be mechanical joint ductile iron fittings.

c. Ductile iron pipe and fittings shall conform to AWWA C-151 and be cement lined and seal coated in accordance with AWWA C-104. The joints of pipe shall be push on joints with rubber gaskets conforming to AWWA C111. Fittings shall have mechanical joints conforming to AWWA C-111 and be cement lined and seal coated in accordance with AWWA C-104. All ductile iron pipe and fittings shall have polywrap in accordance with AWWA C 600.

d. All new service connections shall use a district approved in-line wye type fitting on the public sewer main. Lateral connections to existing sewer shall be made using distort approved gasketed connection such as an "Inserta Tee or other District approved connections. In no case shall the connection protrude into the sewer main.

3. MANHOLES

All manholes shall be concentric manholes constructed of reinforced concrete in sections in accordance with ASTM C478 and as shown on Detail B of these specifications. The concrete shall have a minimum 30 day compressive strength of 4,000 PSI. Manholes shall have a minimum diameter of 48" and have pre-cast manhole bases. Manhole invert channels shall be formed with 4,000 PSI concrete with smooth curves of as large a radius as the size of manhole and pipes permit. The floor of all manholes shall be smooth and slope to the channels therein. Manhole sections shall be jointed with a sealant material in compliance with Federal Specification SS-S-00210. The minimum width of sealant strips shall be 1 inch. All pipe openings through manhole walls shall be grouted inside and outside with no-shrink grout. Manholes shall be sealed on the outside with a two-part urethane modified asphalt applied to provide a dry film thickness of 20 mils. Manhole steps shall have a minimum width of 14 inches and be steel reinforced corrosion resistant polypropylene plastic firmly embedded in the manhole walls, with the top step to be not more than 24" from the finished grade and the step spacing to within 24" of the bottom of the manhole to be 16".

Manhole frames and covers shall be gray iron conforming to ASTM A48. The surfaces shall be machined to provide even seating and shall be coated with coal tar pitch varnish. The minimum clear opening in manhole access openings shall be 22". All manhole covers shall be solid covers with pick holes in two opposing sides for opening. Manhole frame for all manholes shall weigh a minimum of 230 pounds. Manhole lids where traffic loads are possible shall have a minimum weight of 145 pounds. Where there is no possibility of traffic load, manhole lids may be lightweight having a weight of not less than 85 pounds.

4. BEDDING MATERIAL

Bedding material for all sewer pipe and force mains shall be crushed limestone and screenings (3/4" minus) placed as shown on Detail A of these specifications.

5. CASING PIPES

Where sewer pipes cross State Highways, or where required by County or local regulations, all pipes shall be installed in casing pipes, which shall be steel pipe with a minimum

wall thickness of ¼”, unpainted or coated, and shall have a minimum diameter of 10” larger than the nominal size of the sewer pipe. All sewers in casing pipes shall be ductile iron pipe and the ends of casing pipes shall be sealed with preformed seals and/or other material approved by the District Engineer.

6. PIPE SPACERS IN CASING PIPES

Wherever sewers are installed in casing pipes, the pipe shall class 200 ductile iron be supported with “RACT” tape spacers at 6’ intervals, or 3 spacers per 20’ length of pipe. The spacers shall be carefully installed on the pipe before it is installed in the casing pipe.

7. CONCRETE FOR FORCE MAIN THRUST BLOCKS

Concrete for thrust blocking shall be ready mix concrete, composed of Portland cement, sand and gravel with not more than six (6) gallons of water per sack of cement. The concrete shall be a 5-1/2 sack mix with 28 day minimum compressive strength of 3,000 PSI.

8. GRAVITY SERVICE CONNECTIONS

Gravity service connections shall be made in accordance with the District’s sewer service connection policy as described in detail in the District’s “Rules – Requirements for Connections to Water and Sewer Systems.”

9. CONNECTIONS TO FORCE MAINS

Connections to force mains shall be made in accordance with the District’s sewer service connection policy as described in detail in the District’s website “Rules – Requirements for Connections to Water and Sewer Systems.”

10. AIR RELIF VALVES

Air release valves shall have a reinforced nylon body with stainless steel inner working parts and be 2” A.R.I. “Saar” Short Version D-025 or approved equal. All air release valve shall be installed in a 72” diameter manhole.

11. TRACE WIRE ON FORCE MAINS

On all force mains there shall be installed a trace wire which shall be a single insulated No. 12 copper wire, THNN or THWN, gasoline and oil resistant. The insulated wire shall be furnished in rolls of not less than 500 feet. Where splices are required, splices shall be made with 3M splice kits, and no other type of splicing will be allowed.

SECTION II - SEWER SYSTEM INSTALLATION

1. GENERAL

The work covered by this Section of the specifications, shall consist of furnishing all specified materials with all necessary equipment, machinery, tools, and labor, and performing all work required to install and/or construct the sewer system extensions or changes with all directives or modifications and these specifications, all to be; complete, in place, accepted, and ready for use. Failure to comply with these specifications will result in the rejection of the work by the District. All work shall be in accordance with MDNR Rules under Title 10 CSR 20.8-120 and 130.

2. SITE WORK AND PREPARATION

Prior to starting the various sewer route installations, connections, and/or changes as required, the Contractor shall notify the District a minimum of seventy-two (72) hours prior to the start of construction. After so doing, the Contractor shall clear the route of all trees, shrubs, and other objects or materials that may directly interfere with the construction. It is assumed that all other utility companies or organizations have been notified for location of their respective facilities prior to starting any work. All trees, shrubs, bushes, etc., which will not interfere with the construction shall be protected from damage. Work preparations shall include having all necessary material items, equipment, and an adequate labor force at the site in working condition, and completely instructed and prepared to perform the work to completion as required.

3. DRAINAGE

The Contractor shall control the grading in the vicinity of the pipe trenches so that the surface of the ground will be properly sloped to prevent water from running into the excavated areas. Any water or other liquid wastes that accumulate in the excavated areas shall be promptly removed.

4. STAKING

The staking for all sewers and force mains shall be provided or supervised by the developer's Engineer or Land Surveyor. Stakes shall be placed at the offset requested by the Contractor and shall consist of 2" x 2" hubs with 1" x 2" witness laths. The adjacent property lines, easement lines or road right of way lines shall also be staked with laths clearly marked. The witness laths for the sewer stakes shall have the station and the cut clearly marked on them.

The alignment for gravity sewers and force mains and the locations of manholes and air relief valve shall be established from stakes provided therefore. The grades for gravity sewers

shall be established by laser or other means approved by the District Engineer. The grades for force mains shall be established from the cuts shown on the stakes and shall be such that at least 3'-6" cover is provided and provisions are made to clear other utilities or other obstructions.

5. SEPARATION OF WATER MAIN AND SEWERS

Sewers shall be laid at least 10 feet horizontally from any existing or proposed water main or appurtenance. The distance shall be measured edge to edge. In cases where it is not practical to maintain a ten-foot separation, deviations may be made on a case-by-case basis, if supported by data from the design engineer. Such deviation may allow installation of the water main closer to a sewer, provided that the water main is laid on a separate trench or on an undisturbed earth shelf located on one side of the sewer and in either case, at such elevation that the bottom of the water main is at least 18 inches above the top of the sewer.

Sewers crossing water mains shall be laid to provide a minimum vertical clear distance of 18 inches between the outside of the water main and the outside of the sewer. This shall be the case where the water main is either above or below the sewer.

There shall be at least 10 foot horizontal separation between water mains and sanitary sewer force mains. There shall be an 18 inch vertical separation at crossings as required above for gravity sewers.

6. HANDLING OF MATERIALS

All pipe and other accessories, shall be unloaded, stored, re-handled, and installed by methods in such a manner as to insure their final location in a sound and undamaged condition, conforming in all respects to specified requirements. Under no circumstances shall pipe or other accessories, be dropped to the ground, or otherwise subjected to possible damage from impact or shock. Such materials shall be loaded by lifting with machine or hoist, or by skidding. Pipe handled on skidways shall not be skidded or rolled against other pipe.

Under all circumstances, all materials for use shall be handled in a workman-like manner, using the necessary manpower and equipment to perform the task in accordance with the manufacturer's recommendations.

Proper equipment, tools, facilities, and methods satisfactory to the Water District, shall be provided and used by the Contractor for the safe handling of all materials. Under no circumstances shall any materials be dropped or dumped into the trench.

7. TRENCH EXCAVATION AND BACKFILLING

Trenches for sewers and force mains shall have a minimum width of 18” or the pipe O.D. plus 12 inches (whichever is greater), and a maximum width of the pipe O.D. plus 24 inches. The trench depth shall be excavated 6” deeper than the proposed bottom of the pipe to allow for a 6” granular bedding of compacted $\frac{3}{4}$ ” minus rock (See detail A of these specifications). The pipe shall also have the compacted granular material placed to a level 6” above the top of the pipe with care taken to fill all void spaces beneath the pipe.

If the trench bottom contains frozen material, excessive moisture, debris or other deleterious material, the trench shall be excavated 6” or more deeper than the proposed trench bottom and backfilled to the desired grade with compacted $\frac{3}{4}$ ” minus bedding material. For all pipe, bell holes in the trench bottom shall be provided to allow full contact of the pipe with the trench bottom.

The maximum depth for SDR 35 PVC sewers shall be 20 feet. For sewers from 20 feet to 30 feet deep, the pipe shall be ductile iron or SDR 21 PVC. Sewers deeper than 30 feet will not be allowed except where specifically authorized by the District. Generally the maximum slope of sewers shall not be greater than 10%, but if a steeper slope is needed, provisions shall be made to prevent the pipe from moving down the slope in a manner approved by the District. Sewers shall not be closer than 5 feet to any building. The deflections of sewers at any manhole shall not exceed 90 degrees.

Backfill for all pipes under roadways, driveways or parking lots shall consist of 1” clean crushed limestone carefully placed to avoid future settlement from 6” above the top of the pipe to the pavement subgrade. In other areas, the backfill may be excavated earth, free of large stones, frozen material, vegetation or debris. Backfilling of all pipe shall be well compacted by means of jetting or other approved methods to eliminate settling. Any completed areas that show settlement shall be promptly re-backfilled with compacted clean earth or compacted 1” clean rock as required for the initial backfill. Refer to Detail A of these specifications.

8. PIPE INSTALLATION

Laying of the pipe shall commence immediately after the excavation is started, and the Contractor shall use every possible means to keep the completed pipe installation closely behind the trenching. The Water District may stop the trenching if it appears that the trench is open too far in advance of the pipe laying operation. The Contractor may lay pipe in the best manner adapted to securing speed and good results. The Contractor shall have the necessary equipment and tools available for making the joints for the specific materials being used. The pipe connections into manholes shall be grouted with non-shrink grout to ensure a watertight fit.

Gravity sewer pipes lines shall be laid straight to line and grade and carefully controlled by means of the stakes provided and a laser or other approved manner. Force mains shall be laid straight to line and grade with major deflections to be made by appropriate bends.

9. TRACE WIRE INSTALLATION ON FORCE MAINS

The Contractor shall furnish all materials and install the force main trace wire as specified under the previous Section of these specifications. The No. 12 insulated wire shall be placed along the top of the force main and taped in place with duct tape or electrical tape at a maximum of 6' intervals. After installation and trench backfilling, the trace wire shall be tested for continuity by the contractor. Permanent access points shall be provided through manholes, valve boxes or other approved means at the ends of the trace wire.

10. MANHOLE INSTALLATIONS

All manholes shall be installed as shown in the details of these specifications and at the locations and to the grades shown on the plans. The maximum spacing between manholes shall be 500 feet and where possible, manholes shall be located on side property lines. After the bottom section of each manhole has been installed, the invert shall be shaped as specified in Section I, Paragraph 3 of these specifications. After the manhole has been fully installed, all lifting holes shall be filled with non-shrink grout and the outside of the manhole shall be sealed as called for in Section I, Paragraph 3 of these specifications. Care shall be taken to ensure that the flowline grade and finished grades are accurately established as shown on the plans. The manhole frames and covers shall conform to any slope of the ground or pavement.

All pipe openings in the manholes shall be carefully filled with no-shrink grout inside and outside of the manhole. If rubber or plastic seals are provided, these shall be completely covered with grout. Backfilling of the manholes shall be done carefully to ensure that no movement of the manhole occurs.

All elevation differences of two (2') feet or more where the pipe enters the manhole shall require an outside drop manhole (See Detail "C" of these Specification).

11. WORK ADJACENT TO AND/OR CROSSING STATE OR COUNTY HIGHWAYS

All work to be performed within the right-of-way limits of the State and/or County Highways shall be performed in strict accordance with the Highway Department requirements.

The Contractor shall obtain the necessary permits for all work prior to starting any construction. All permits must be displayed as required.

The Contractor shall comply with all requirements such as; signals, flagman, and watchmen; performance of work in such a manner so as not to interfere with traffic, highway entrances, highway maintenance, highway drainage, etc., and methods of placing material, backfill compaction, and all such other requirements, which may differ from or may be in addition to those specified for work other than that within the highway right-of-way limits.

Highway crossings shall be constructed in accordance with all permit requirements.

The Contractor will be held responsible for any and all expense incurred by the Highway Department in protecting the highway while construction is in progress, or as a result of said construction.

The Contractor will also be held responsible for all damages to the highway due to operations during construction including replacement of damaged pavement. Crossings shall be

machine bored with simultaneous installation of the encasement. Boring without the concurrent installation of the encasement tube will not be permitted. All joints of the encasement tube shall be welded as specified and the encasement tube shall extend to the required dimensions.

Following completion of the machine bored crossing, the ends of the pipe casings shall be sealed and all bore pit or other required excavation shall be suitably backfilled to grade. All debris, of whatever nature, shall be picked up and removed from the site. After clean-up, the disturbed area shall be smoothed to grade, seeded, and covered with straw.

The entire work area shall be left in an orderly and acceptable condition.

12. CREEK CROSSINGS

In general, creek crossings shall be made with PVC pipe with a minimum of 3-1/2 feet of cover. If the grades are such that the cover is less than 3-1/2 feet, the pipe shall be encased in concrete, be ductile iron pipe or both as called for on the plans.

Aerial crossings will be allowed only with special permission of the District Engineer and shall be ductile iron pipe with concrete supports all as detailed on the plans.

13. INSTALLATION OF AIR RELIEF VALVES AND VAULTS

Air relief valves shall be provided on force mains at all high points and as indicated on the plans. The vaults shall be flat bottom 72" diameter manholes. The air relief valves shall be installed on the top of the pipe and shall have a 2" stainless steel gate valve or globe valve between the force main and the air relief valve. The air relief valves shall be firmly attached to the sides of the manhole with stainless steel straps attached to the sides of the manhole to prevent movement of the valve during operation. The piping for the air release valve and all fitting shall be stainless steel.

14. INSPECTION AND TESTING

All sewer system work shall be conducted under the inspection of a representative of the District. All work may not require inspection but the District's representative may designate specific areas that must be inspected before the work is backfilled. All testing must be witnessed by the District's Inspector and the Contractor shall furnish all testing equipment as approved by the District. Testing shall include:

a. A mandrel test of all gravity sewers using a mandrel with a diameter that has a diameter 95% of the inside pipe diameter. If the mandrel test fails on any section of pipe, that section of pipe shall be uncovered and replaced. No expansion devices will be allowed to be used to "force" the pipe that is deformed back into round. Any string lines used in mandrel testing shall be removed after the testing is completed.

- b. An air pressure test of all gravity sewers shall be in accordance with ASTM F1417 as required by 10 CSR 20-8.120(3)(C)2.8.
- Air pressure priming, where air is introduced to a pressure of 4.0 psig, stabilized between 3.5 and 4.0 psig for 2 minutes prior to the test period, and then the test is run at a pressure of 3.5 psig
 - Mechanical or pneumatic plugs with bracing to isolate the test section; and
 - An oil free air source with main shut-off valve, pressure-regulating valve, 9 psig pressure-relief valve, input pressure gauge, and continuous monitoring pressure gauge having a pressure range from 0 psi to at least 10 psi with minimum division of 0.10 psi and an accuracy of ± 0.04 psi.
- c. A vacuum test of all manholes shall be in accordance with ASTM C1244.
- d. Force mains shall be pressure tested at a pressure of 150 PSI for a period of 2 hours with a maximum of not more than 2 PSI drop in pressure.
- e. The trace wire on all force mains shall be tested by the Contractor for continuity.

15. SITE CLEANUP, RESTORATION AND GRADING

After work is completed, the site of all sewer system installations shall be cleared of all construction material and other debris. Grading on the developer's property shall be as agreed upon between the Developer and the Contractor but shall consist of a minimum of rough grading to provide proper drainage and all sites shall be left in a neat, clean and acceptable condition. For all sewer work in easements or other property other than the property of the Developer, the site shall be restored to a condition equal to, or better than, the condition before the work was started. In any lawn areas, the final restoration shall include sodding.

16. AS BUILT DRAWINGS

During the course of the work, the Contractor must have in his possession at all times a copy of the Plans approved by the District. As work progresses, the Contractor shall note all lengths of pipe installed, flow lines at all manholes, locations of all manholes, air relief valve vaults, and service connections and record all dimensions necessary to locate all sewer system facilities. At the completion of the project, and prior to acceptance by the District, the Contractor shall furnish the copy of plans where all "as built" dimensions and notes are endorsed. The plans must be relatively clean and totally legible regarding all notes made thereon.

17. GUARANTEE

The Contractor shall guarantee all material and workmanship for a period of a minimum of three (3) years following acceptance of the work by the District.

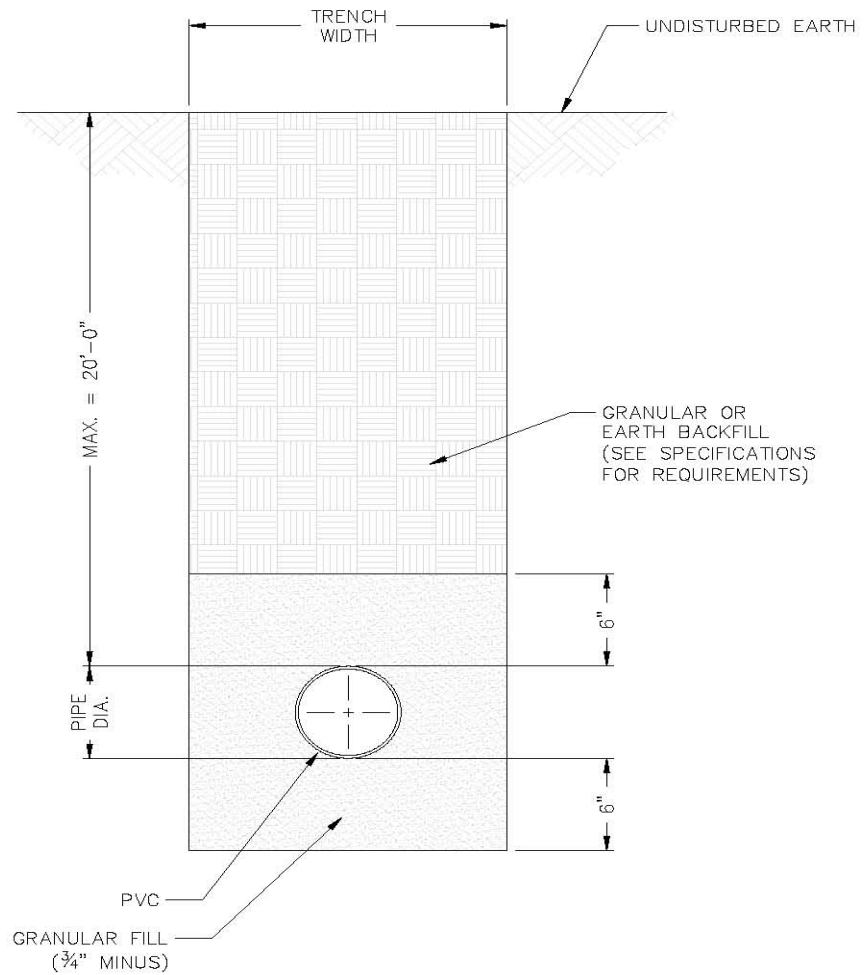

NOTE: SEE SPECIFICATIONS FOR ADDITIONAL DETAILS FOR BEDDING AND BACKFILL.

TYPICAL TRENCH SECTION
NOT TO SCALE
DETAIL "A"

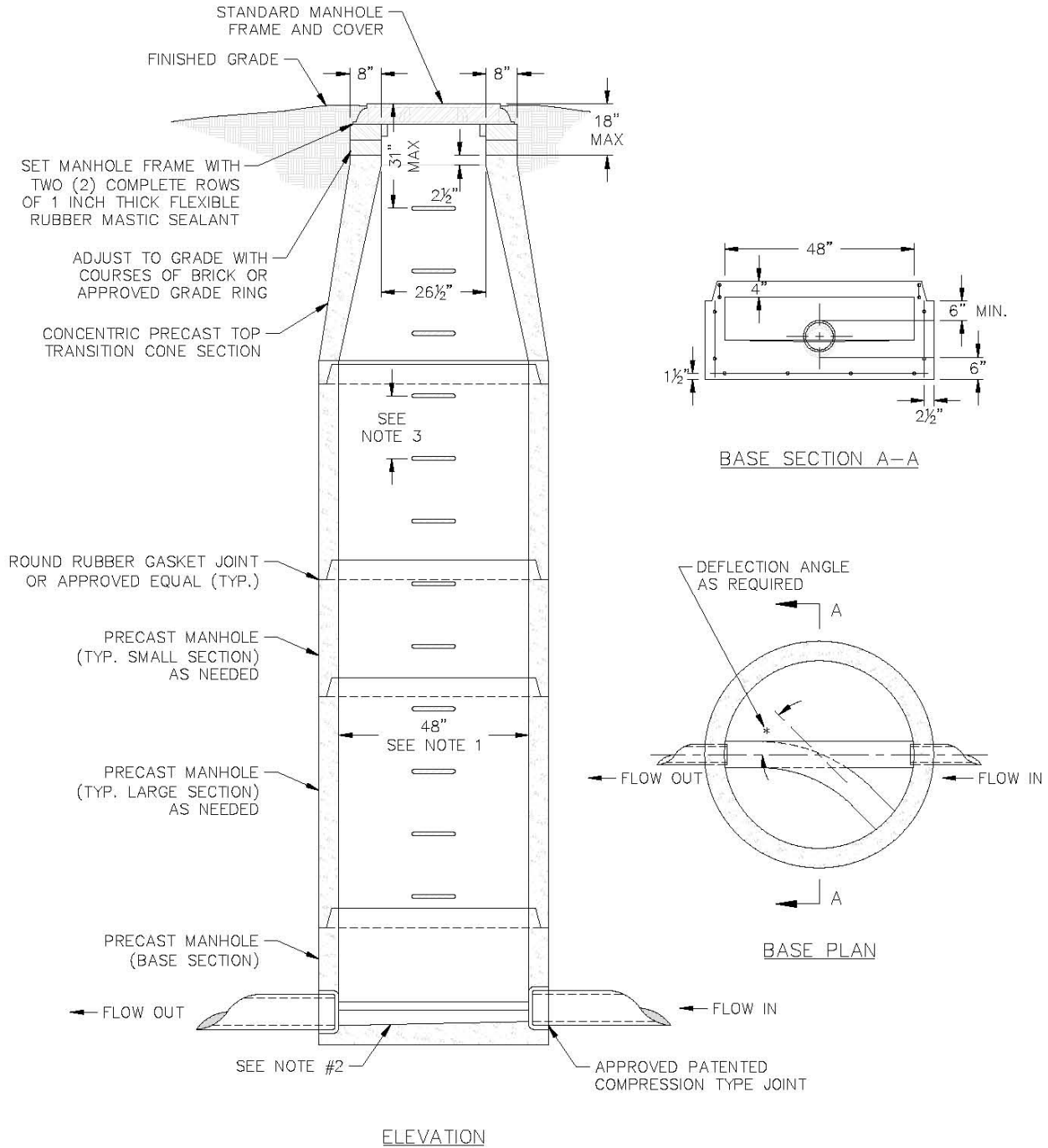

NOTES:

- 1) THE MINIMUM INSIDE DIAMETER FOR THE BASE AND RISER SECTIONS SHALL BE 48" FOR ALL SANITARY SEWERS. MANHOLE SHALL MEET ASTM C-478 REQUIREMENTS.
- 2) FLOW LINE ELEVATION OF INCOMING PIPES SHALL BE 1 INCH HIGHER THAN THAT OF OUTGOING PIPE.
- 3) SHAFT STEPS UNIFORMLY SPACED AT 16" O/C. STEPS SHOULD NOT BE OVER TOP OF PIPES AND SHALL EXTEND 4 1/2" FROM WALL.

TYPICAL MANHOLE
NOT TO SCALE
DETAIL "B"

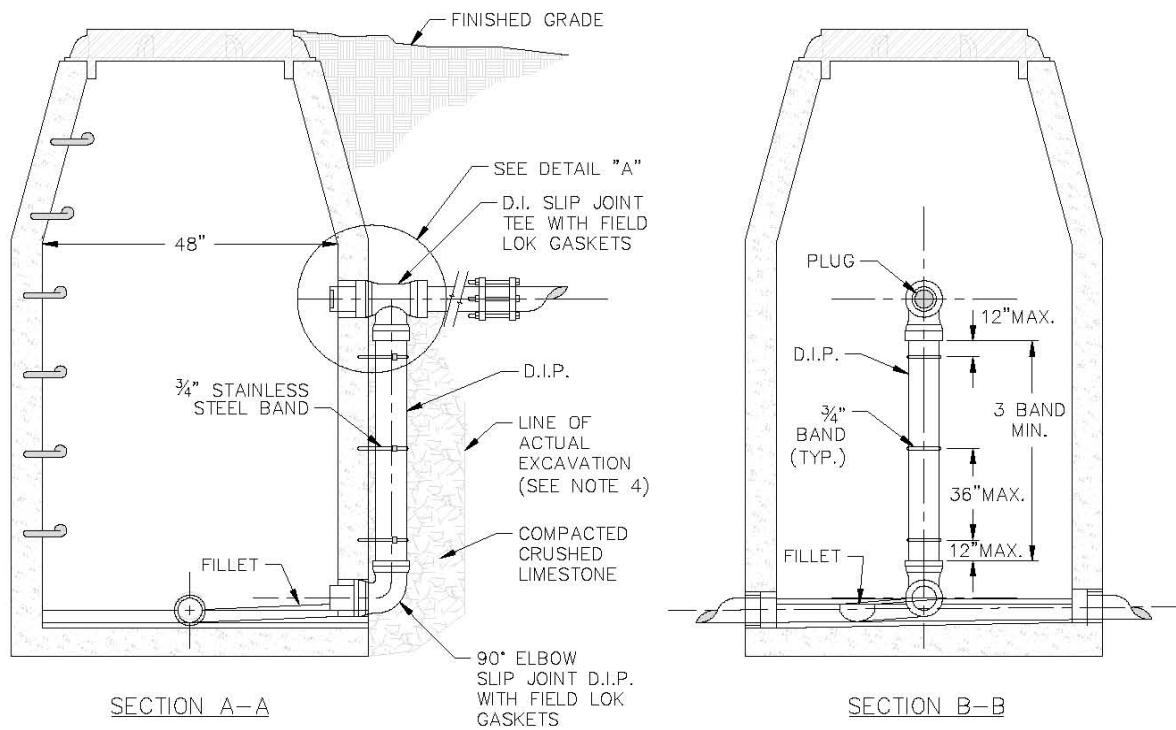
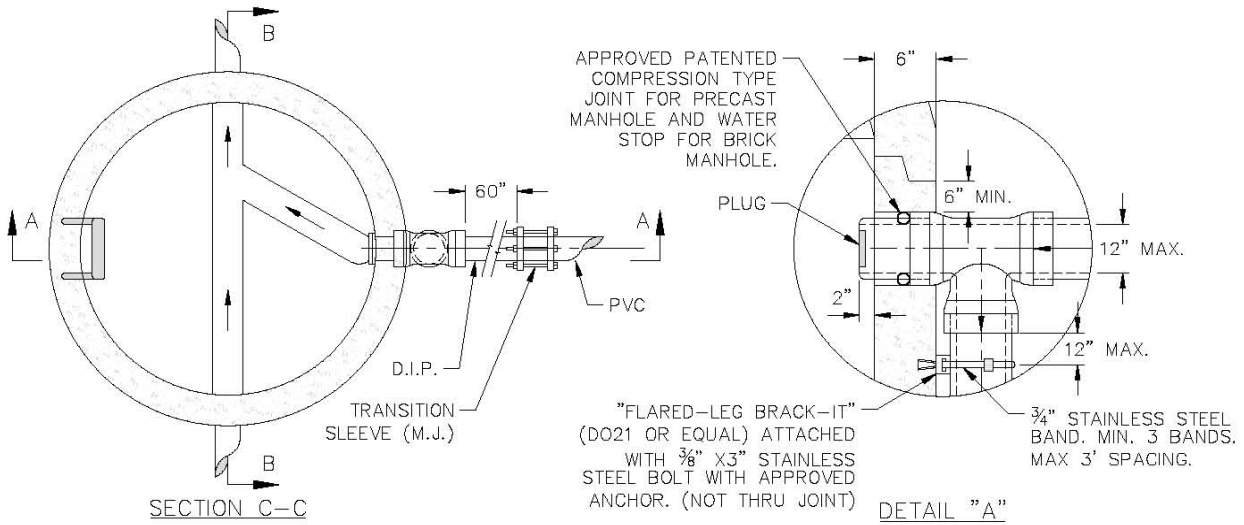

NOTES:

- 1) THE MINIMUM INSIDE DIAMETER FOR THE BASE AND RISER SECTIONS SHALL BE 48" FOR ALL SANITARY SEWERS.
- 2) NEW OUTSIDE DROP ON EXISTING MANHOLE REQUIRES THAT THE FLOW LINE OF THE NEW DROP PIPE ELBOW BE CONSTRUCTED AT THE SAME ELEVATION AS THE SPRINGLINE OF THE EXISTING SEWER MAIN AT THE CENTER OF THE EXISTING MANHOLE. A CLASS "A" CONCRETE FILLET AND INVERT SHALL BE CONSTRUCTED FOR DROP PIPE.
- 3) DIAMETER OF DROP PIPE FOR COMBINED SEWERS AND SANITARY SEWERS IS THE SAME AS INCOMING PIPE SEWER UNLESS OTHERWISE SHOWN ON PROJECT PLANS.
- 4) IF EXCAVATED SPACE OUTSIDE OF DROP PIPE EXCEEDS ONE FOOT (1'), PROVIDE 6" CLASS "A" CONCRETE ENCASEMENT ON INCOMING LINE FROM WALL OF MANHOLE TO A MINIMUM OF TWO FEET INTO UNDISTURBED EARTH WITH A MINIMUM OF 4-#4 REBARS FOR THE LENGTH OF ENCASEMENT.

TYPICAL DROP MANHOLE

NOT TO SCALE
DETAIL "C"

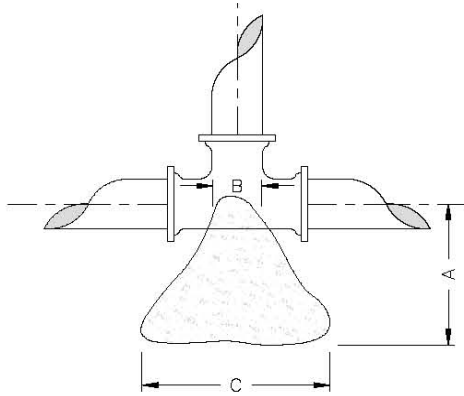

TEES AND TAPPING
SLEEVE
NOT TO SCALE

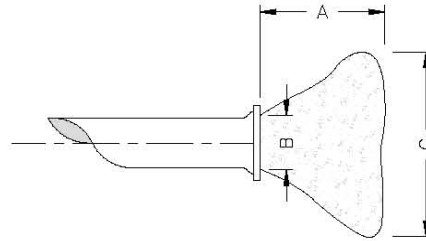

PLUGS
NOT TO SCALE

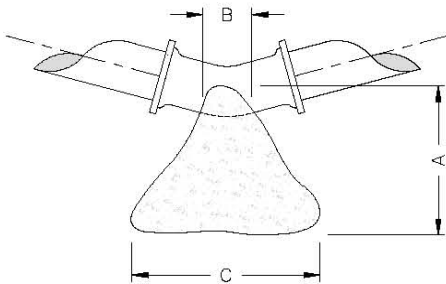

BENDS
NOT TO SCALE

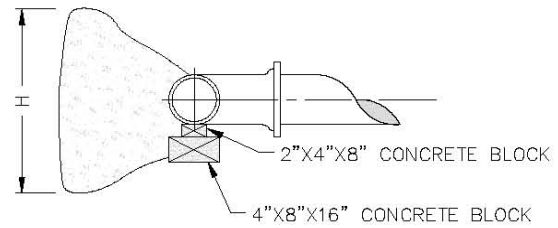

TYPICAL SECTION
NOT TO SCALE

| THRUST BLOCK DIMENSIONS - INCHES | | | | | | | | | | | | |
|----------------------------------|-----------|----|------------------|----|----------------|----|----------------|----|-------------|----|-------------|----|
| PIPE DIA. | ALL FTGS. | | TEE PLUG TAPPING | | 90 DEGREE BEND | | 45 DEGREE BEND | | 22-1/2 BEND | | 11-1/4 BEND | |
| | A | B | C | H | C | H | C | H | C | H | C | H |
| 4 | 14 | 4 | 24 | 12 | 26 | 15 | 18 | 12 | 12 | 12 | 12 | 12 |
| 6 | 16 | 6 | 36 | 18 | 36 | 24 | 30 | 18 | 24 | 12 | 12 | 12 |
| 8 | 20 | 8 | 36 | 30 | 42 | 36 | 36 | 24 | 24 | 18 | 18 | 12 |
| 10 | 20 | 10 | 48 | 36 | 66 | 36 | 36 | 36 | 28 | 24 | 18 | 18 |
| 12 | 24 | 12 | 68 | 36 | 82 | 42 | 52 | 36 | 40 | 24 | 28 | 18 |

NOTE: FOR FITTINGS LARGER THAN 12", SPECIAL RESTRAINT DESIGNS ARE REQUIRED.

HORIZONTAL THRUST BLOCKING
FOR FORCE MAINS
DETAIL "D"

THRUST BLOCK DIMENSIONS - INCHES

| PIPE DIA. | ALL FTGS. | | 45 DEGREE BEND TEE PLUG TAPPING 90 DEGREE BEND | | | | 22-1/2 BEND | | 11-1/4 BEND | | | |
|-----------|-----------|----|--|------|------|----|-------------|----|-------------|----|----|----|
| | AB | | CH | CHC | HC | HC | HC | H | | | | |
| 4 | 14 | 4 | 2412 | 2615 | 1812 | | 1212 | | 1212 | | | |
| 6 | 16 | 6 | 3618 | 3624 | 3018 | | 2412 | | 1212 | | | |
| 8 | 20 | 8 | 3630 | 4236 | 3624 | | 2418 | | 1812 | | | |
| 10 | 20 | 10 | 48 | 36 | 66 | 36 | 36 | 28 | 24 | 18 | 18 | |
| 12 | 24 | 12 | 68 | 36 | 82 | 42 | 52 | 36 | 40 | 24 | 28 | 18 |